

CRANKSET REMOVAL (Cont.)

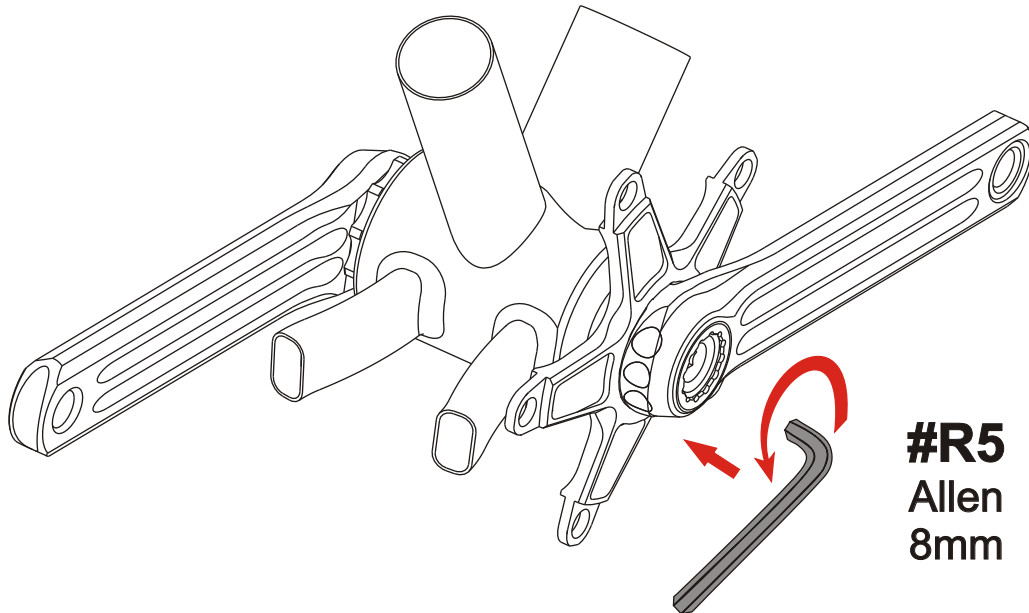
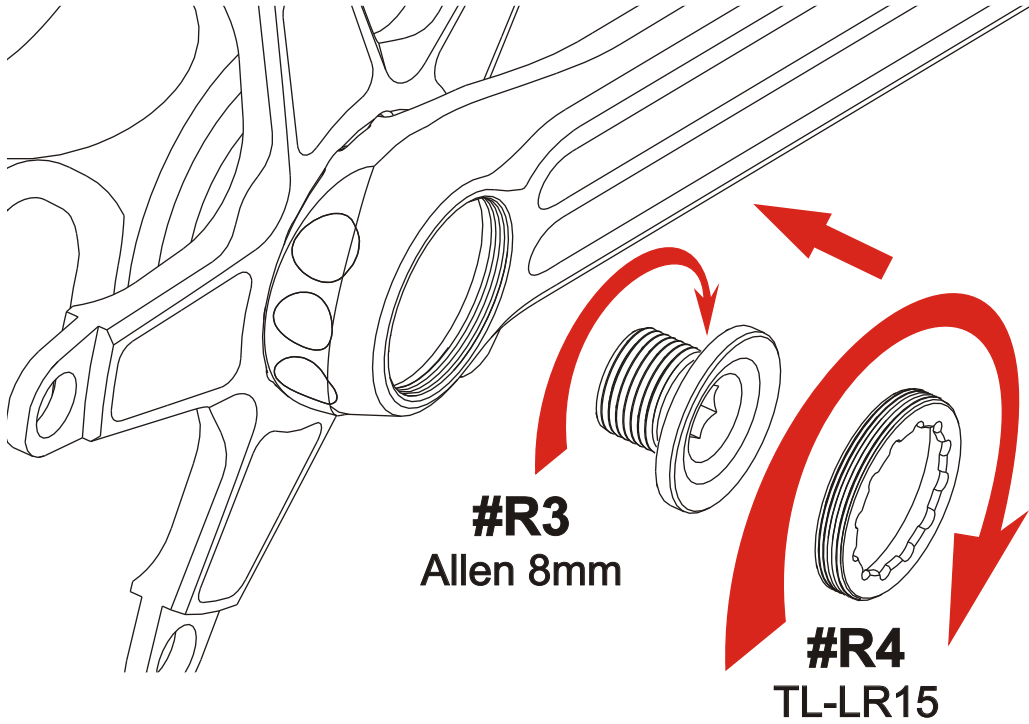

ROTOR COMPONENTES TECNOLÓGICOS SL
Pol.Ind. Conmar. C/Miño, 16-18. 28864, Ajalvir, Madrid, Spain.
Phone: +34 91 884 38 46
Fax: +34 91 884 38 65
info@rotorbike.com

3D30 INSTALLATION GUIDE FOR CERVÉLO BB Right frames

(OEM purpose only; Contact us for aftermarket manual)

Revised 07/2010

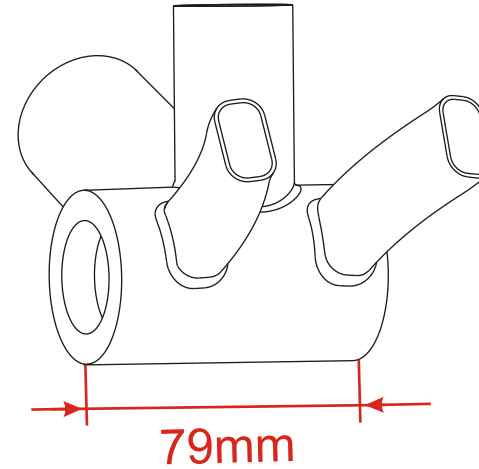

#1. Non Drive-side Assembly Installation.

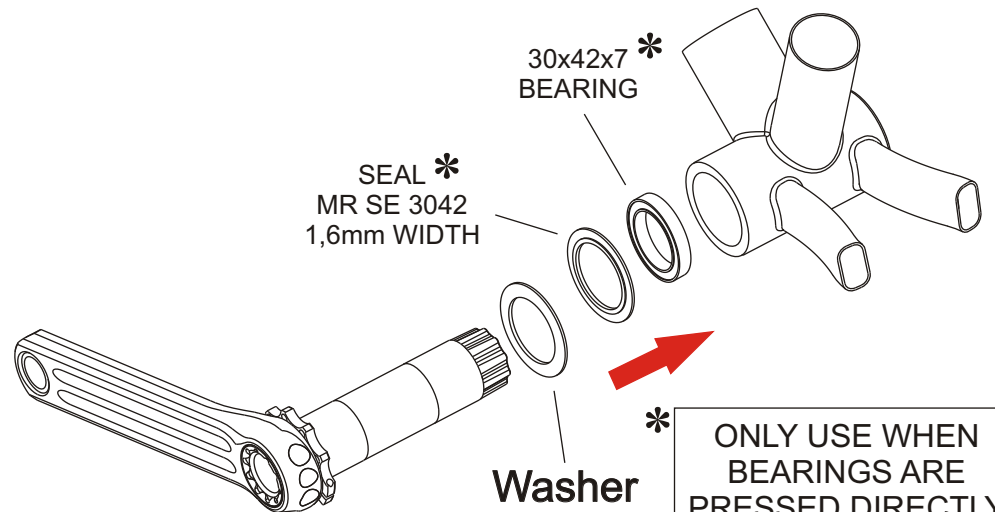

* ONLY USE WHEN
BEARINGS ARE
PRESSED DIRECTLY
INTO THE FRAME.

#2. Drive-side Assembly Installation.

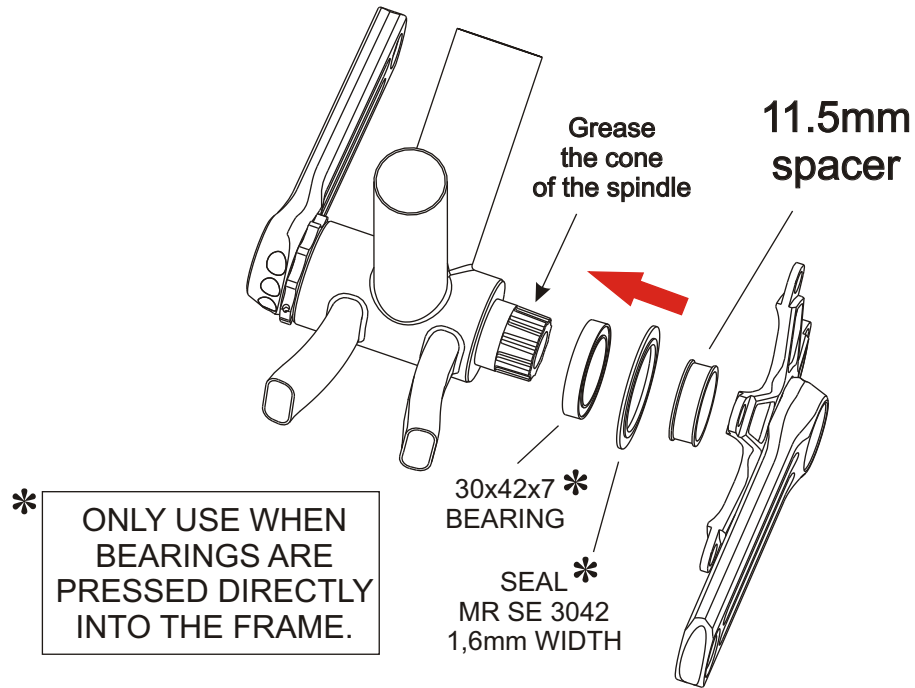

#3. Fixing of Drive-side Assembly.

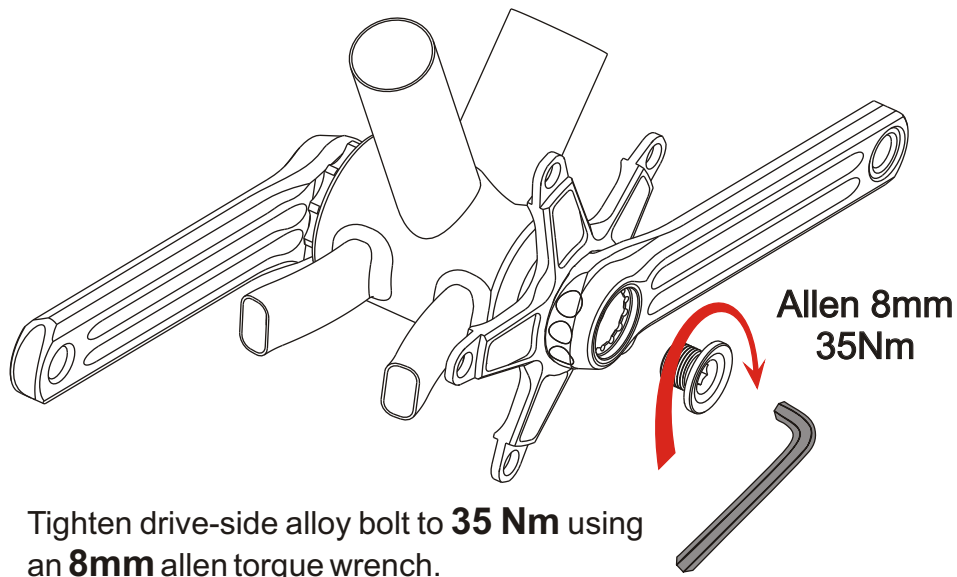

#4. Preload adjustment.

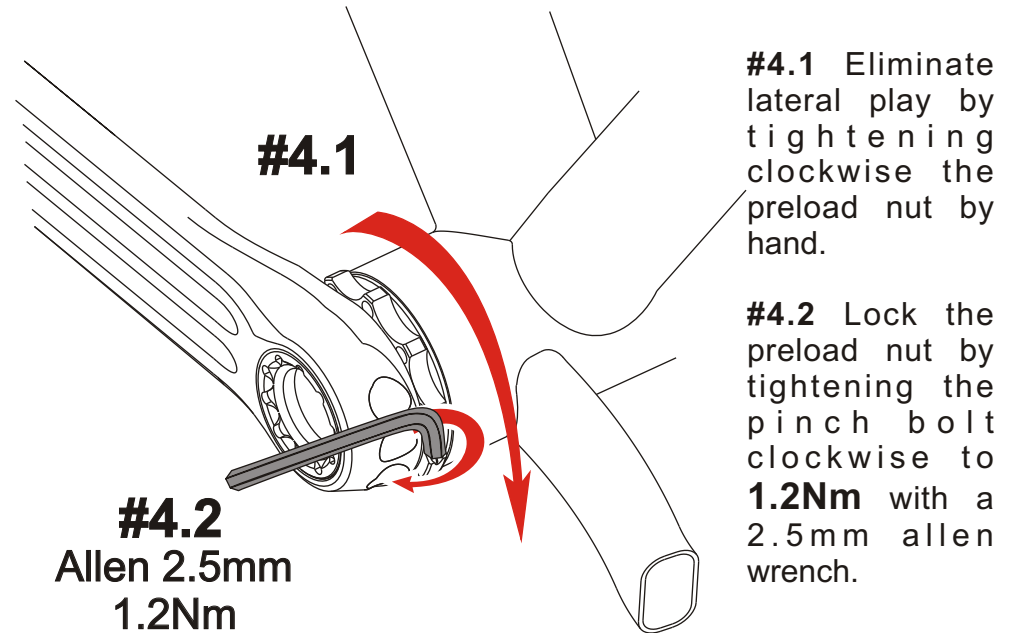

CRANKSET REMOVAL

- #R1. Remove drive-side alloy bolt.
- #R2. Remove drive-side steel nut using a cassette locking tool (Shimano TL-LR15 or similar).
- #R3. Screw the drive-side alloy bolt clockwise into the spindle.
- #R4. Flip the drive-side nut over and screw it clockwise into the crank arm to be used as a self-extracting cap.
- #R5. Unscrew the drive-side alloy bolt counter-clockwise using a 8mm allen wrench until the drive-side assembly disengages from the spindle.